

5 Frame Plunger Pump

Models

42HS
43HS

FEATURES

Superior Design

- Triplex plunger design gives smoother fluid flow.
- High pressure seals are completely lubricated and cooled by the fluid being pumped.
- Inlet and discharge valve assemblies interchange for easier maintenance.
- Lubricated low pressure seal provides double protection against external leakage.
- Oil bath crankcase assures optimum lubrication.
- Close tolerance concentricity of the ceramic plunger maximizes seal life.
- Optional Gearbox or Flexible Coupling version for direct mounting to gas engine.

Quality Materials

- All stainless steel valves are heat treated and seats are roller burnished for a positive seal and extended valve life.
- Forged brass manifold for strength and corrosion resistance.
- Special hardened, polished surface of solid ceramic plunger is abrasion resistant and results in extended seal life.
- Specially formulated, CAT PUMP exclusive, Hi-Pressure Seals offer unmatched performance and seal life.
- Die cast aluminum crankcase provides high strength, minimum weight and precision tolerance control.
- Chrome-moly crankshaft gives unmatched strength and surface hardness.
- Oversized crankshaft bearings with greater loading capacity means longer bearing life.

Easy Maintenance

- Wet end is easily serviced without entering crankcase, requiring less time and effort.
- Valve assemblies are accessible without disturbing piping, for quick service.
- Preset packings mean no packing gland adjustment is necessary, reducing maintenance costs.

DETERMINING THE PUMP R.P.M. $\frac{\text{Rated G.P.M.}}{\text{Rated R.P.M.}} = \frac{\text{"Desired" G.P.M.}}{\text{"Desired" R.P.M.}}$

DETERMINING THE REQUIRED H.P. $\frac{\text{GPM} \times \text{PSI}}{1460} = \text{Electric Brake H. P. Required}$

DETERMINING MOTOR PULLEY SIZE $\frac{\text{Motor Pulley O.D.}}{\text{Pump R.P.M.}} = \frac{\text{Pump Pulley O.D.}}{\text{Motor R.P.M.}}$

Note: Consult engine manufacturer when using gas or diesel engine. Refer to pump Service Manual for important Inlet Condition Check-List, Start-up Procedure, Tech Bulletins and Pump Maintenance information.

SPECIFICATIONS

	U.S. Measure	Metric Measure
MODEL 42HS		
Volume	4.5 GPM	(17 L/M)
Dchg. Pressure	100 to 2000 PSI	(7-140 BAR)
RPM	3600 RPM	(3600 RPM)
Bore.....	0.630"	(16 mm)
Stroke.....	0.335"	(8.5 mm)

MODEL 43HS

Volume	4.0 GPM	(15 L/M)
Dchg. Pressure	100 to 3000 PSI	(7-210 BAR)
RPM	3300 RPM	(3300 RPM)
Bore.....	0.551"	(14 mm)
Stroke.....	0.433"	(11 mm)

COMMON SPECIFICATIONS

Maximum Inlet Pressure	Flooded to 60 PSI	(0.35 to 4 BAR)
Crankcase Capacity	18 oz.	(0.55 L)
Maximum Fluid Temperature	160°F	(71°C)
Inlet Ports (2)	1/2" NPT	(1/2" NPT)
Discharge Ports (2).....	3/8" NPT	(3/8" NPT)
Shaft Diameter.....	0.787"	(20 mm)
Weight	20.9 lbs.	(9.5 kg)
Dimensions.....	12.0"x 8.35"x 5.5"	(304.5 x 212 x 139 mm)

HORSEPOWER REQUIREMENTS

MODEL	FLOW		PRESSURE					RPM	DRIVE
			PSI	PSI	PSI	PSI	PSI		
			1500	2000	2500	3000	3500		
	U.S. GPM	L/M	BAR	BAR	BAR	BAR	BAR		
42HS	4.5	17	4.7	6.2	N/A	N/A	N/A	3600	B.H.F.C.
	4.0	15	4.1	5.5	N/A	N/A	N/A	3200	
	3.75	14	3.9	5.2	6.5	N/A	N/A	3600	
43HS	4.0	15	4.1	5.5	6.9	8.24	N/A	3300	B.H.F.C.
	3.6	13	3.7	5.0	6.2	7.4	N/A	3000	
	3.0	11	3.1	4.2	5.2	6.2	N/A	2500	

See complete Drive Packages [Incls: Pulleys, Belts, Hubs, Key] Tech Bulletin 03.

"Customer confidence is our greatest asset"

PARTS LIST

Item	Part Number		Description	Qty
	Model 42HS	Model 43HS		
2	30057	30057	Key (M6)	1
5	● 96031 Z	96031 Z	Screw, Sems Comb.Head (M8 x 16), Bearing Case	8
8	● 45951 A	45951 A	Bearing Case (M8) - O.E.M.	1
10	43343 B	43343 B	O-ring, Bearing Case	2
11	43222 B	43222 B	Oil Seal, Crankshaft	1
15	14480	14480	Bearing	2
20	45883 ZZ	45883 ZZ	Connecting Rod Assy	3
25	45782	45889	Crankshaft - Single End	1
30	● 45953 A	45953 A	Blind Shaft Cover (M8) - O.E.M.	1
32	44666	44666	Oil Filler Cap, Domed	1
33	14177 B	14177 B	O-Ring, Oil Filler Cap	1
37	43987	43987	Oil Gauge, Bubble	1
38	44428 B	44428 B	Gasket, Flat	1
40	92519 Z	92519 Z	Screw, Sems Comb. Head (M6x16)	4
48	25625 Z	25625 Z	Drain Plug	1
49	23170 B	23170 B	O-Ring, Drain Plug	1
50	44222 A	44222 A	Crankcase Cover - O.E.M.	1
51	43340 B	43340 B	O-Ring, Crankcase Cover	1
53	● 45966 A	45966 A	Crankcase (M8) - O.E.M.	1
64	43351 S	43351 S	Pin, Plunger Rod	3
65	45908 SZZ	45908 SZZ	Plunger Rod	3
70	43228 B	43228 B	Oil Seal, Crankcase	3
75	43328 S	43328 S	Barrier Slinger	3
88	45697 S	45697 S	Washer, Keyhole	3
90	45783 CC	45890 CC	Plunger, (M72)	3
95	89648 Z	89648 Z	Stud, Plunger Retainer (M6 x 64.5) - O.E.M.	3
96	43235 T	43235 T	Back-up Ring, Plunger Retainer	3
97	17399 B	17399 B	O-Ring, Plunger Retainer	3
	14160 V	14160 V	<i>O-Ring, Plunger Retainer</i>	3
98	45891 CU	45891 CU	Gasket, Plunger Retainer	3
99	46504 BB	46504 BB	Plunger Retainer	3
100	45681 P	45681 P	Seal Retainer-Rear	3
	45687 P	45687 P	Seal Retainer-Adapter-Front	3
106	43316 BTS	45188 BTS	Lo-Pressure Seal w/Spring	3
	— V	— V	<i>Lo-Pressure Seal w/Spring</i>	3
120	45789 BB	45897 BB	Seal Case	3
121	14200 BB	14200 BB	O-Ring, Seal Case	3
	11719 V	11719 V	<i>O-Ring, Seal Case</i>	3
125	45787 BTS	—	Hi-Pressure Seal	3
126	— BB	45896 BB	Female Adapter	3
127	— BT	45895 BT	V-Packing	6
	—	—	<i>V-Packing - White - STG</i>	6
128	— BB	45894 BB	Male Adapter	3
163	17547 B	17547 B	O-Ring, Valve Seat	6
	11685 V	11685 V	<i>O-Ring, Valve Seat</i>	6
164	45790 S	45790 S	Valve Seat	6
166	44057 SS	45899 S	Valve	6
167	43750 S	43750 S	Valve Spring	6
168	44565 P	44565 P	Valve Spring Retainer	6
172	17615 B	17549 B	O-Ring, Valve Plug	6
	26996 V	26996 V	<i>O-Ring, Valve Plug</i>	6
173	— T	20212 T	Back-up Ring, Valve Plug	6
174	44202 BB	45900 BB	Valve Plug - O.E.M.	6
185	45786 BB	45893 BB	Manifold Head - O.E.M.	3
186	12503 Z	12503 Z	Washer, Split Lock	2
188	87931 Z	87931 Z	Bolt, Hex Socket Head (M10x35)	2
277	34156	34156	<i>Bell Housing Assy (M8) (Short)</i>	1
	34159	34159	<i>Bell Housing Assy (M8) (Long)</i>	1
278	34119	34119	<i>Flex. Coupling & Key Assy</i>	1
283	34344	34344	<i>Oil Drain Kit</i>	1
300	30627 B	30628 B	<i>Seal Kit (Incls: 97,106,121,125 or 127)</i>	1
310	30680	30680	<i>Valve Kit (Incls: 163,164,165,166,167,172,173)</i>	2
350	30696	30696	<i>Valve Seat Removal Tool</i>	1
351	43257	43257	<i>Seal Case Removal Tool</i>	1
	33004	33004	<i>Seal Case Socket, 1/2" Drive</i>	1
—	6565.1	6565.1	<i>Plunger Pump Service Video, Section I</i>	1

Bold print part numbers are unique to a particular pump model. Italics are optional items.

See Tech Bulletins 03, 24, 35, 36, and 74 for additional information.

● Effective with 6/91 Production

MATERIAL CODES (Not Part of Part Number): A=Aluminum B=Buna-N BB=Brass

CC=Ceramic CU=Copper N=Nickel Aluminum Bronze P=PVDF S=304SS SS=316SS T=Teflon V=Viton Z=Zinc Plated ZZ=Zamak

EXPLODED VIEW

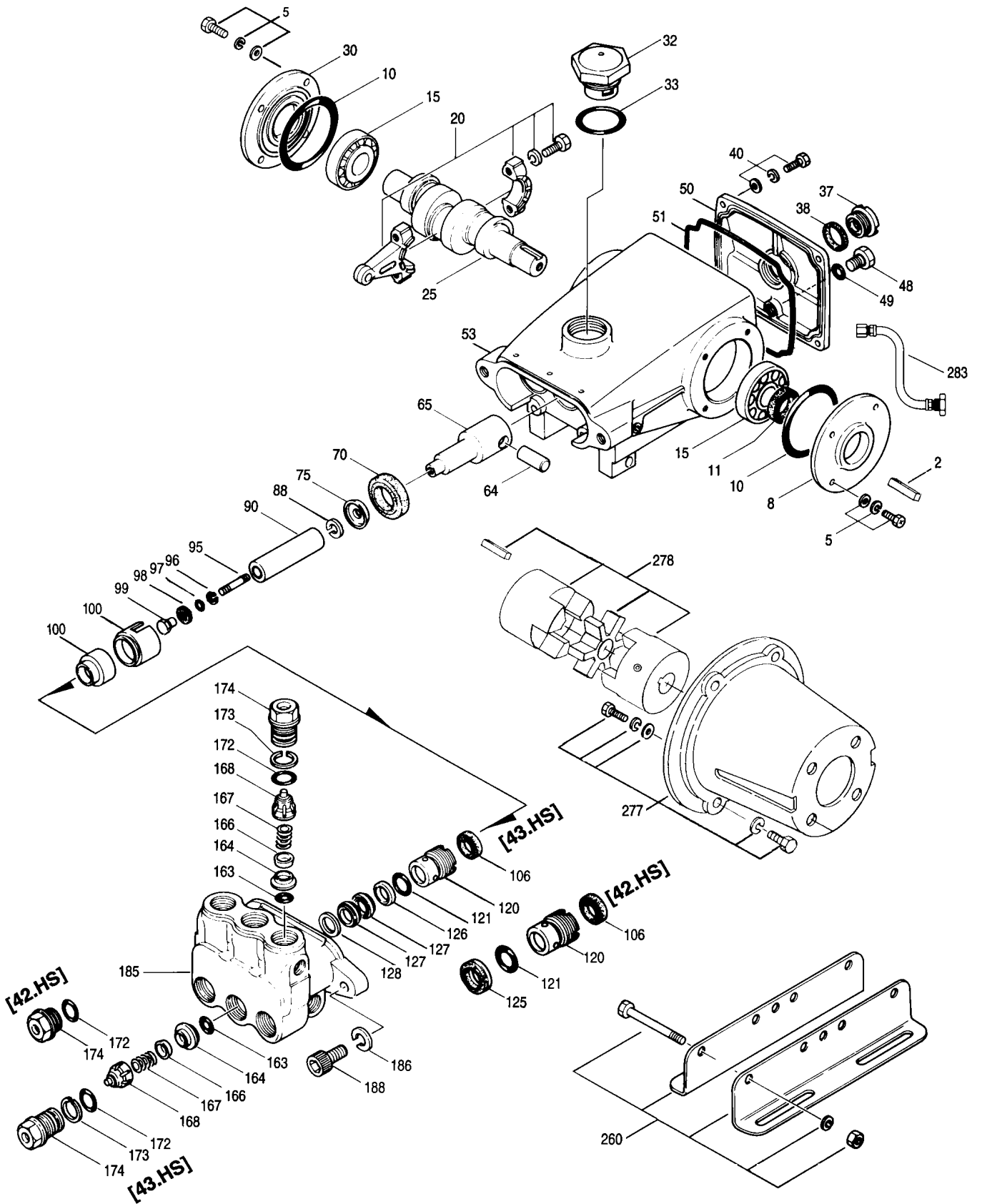

Models
42HS, 43HS
November 1998

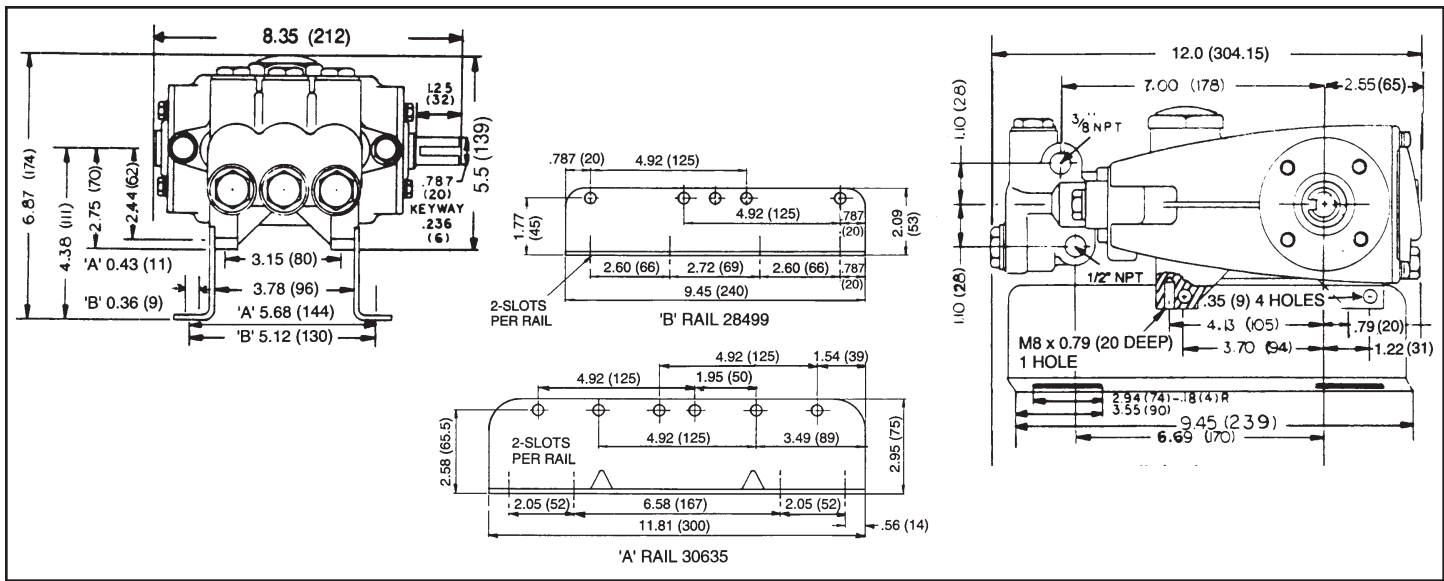

Models 42HS, 43HS

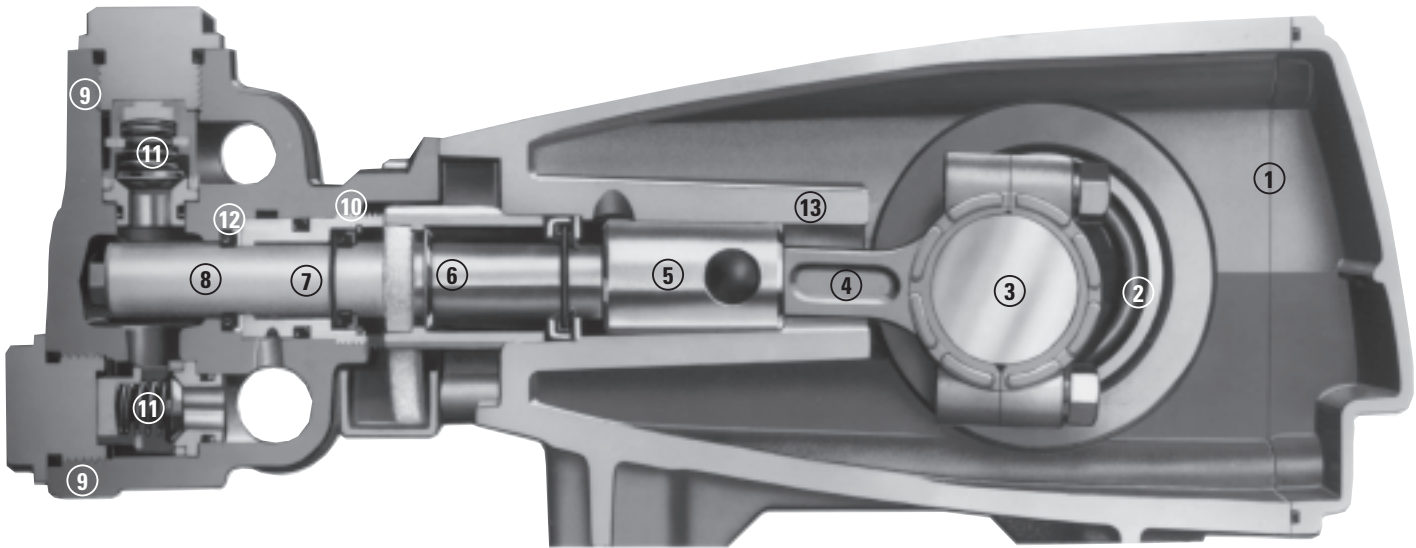

- 1 Die cast aluminum **crankcase** means high strength, lightweight, and excellent tolerance control.
- 2 Oversized crankshaft **bearings** provide extended bearing life and pump performance.
- 3 Chrome-moly **crankshaft** provides unmatched strength and surface hardness for long life.
- 4 Matched oversized **connecting rods** are made of Zamak, a material noted for strength and superior bearing quality.
- 5 The **plunger rods** are high tensile strength stainless steel with Zamak crossheads.
- 6 The stainless steel **slinger** provides back-up protection for the crankcase seal, keeping pumped fluids out of the crankcase.
- 7 Precision-polished solid ceramic **plungers** provide maximum resistance to corrosion and abrasion.
- 8 The close tolerance concentricity of the ceramic **plunger** maximizes seal life.
- 9 **Manifolds** are a high tensile strength forged brass for long term, continuous duty.
- 10 100% wet **seal** design adds to service life by allowing pumped fluids to cool and lubricate on both sides.
- 11 Stainless steel **valves, seats and springs** provide corrosion-resistance, positive seating and long life.
- 12 Specially formulated, CAT PUMP exclusive, **Hi-Pressure Seals** offer unmatched performance and seal life.
- 13 **Crossheads** are 360° supported for uncompromising alignment.

Nov 1998 11840

World Headquarters

CAT PUMPS

1681 - 94th Lane N.E. Minneapolis, MN 55449-4324

Phone (612) 780-5440 — FAX (612) 780-2958

e-mail: sales@catpumps.com

www.catpumps.com

International Inquiries

FAX (612) 785-4443

e-mail: intlsales@catpumps.com



The Pump with "Nine Lives"

CAT PUMPS (U.K.) LTD.

1 Fleet Business Park, Sandy Lane, Church Crookham, Fleet

Hampshire GU13 0BF, England

Phone Fleet 44 1252-622031 — Fax 44 1252-626655

N.V. CAT PUMPS INTERNATIONAL S.A.

Heiveldekens 6A, 2550 Kontich, Belgium

Phone 32-3-450.71.50 — Fax 32-3-450.71.51

e-mail: cpi@catpumps.be

CAT PUMPS DEUTSCHLAND GmbH

Buchwiese 2, D-65510 Idstein, Germany

Phone 49 6126-93030 — Fax 49 6126-930333

e-mail: catpumps@t-online.de